

FLOJET

“Quad II Diaphragm” 4105 & 4125 Series Bait Tank, Diesel Transfer and General Purpose Pump

FEATURES

- Self-Priming
- Dry Running
- Soft, Noise Absorbing Mounts
- Corrosion Resistant Materials
- Meet U.S.C.G. Electric Standards
- 3.3 GPM Model for 15-30 gal. tanks
- 5.0 GPM Model for 30-50 gal. tanks with Thermal Overload Protection

SPECIFICATIONS

Motor: Permanent Magnet, Ball Bearings on both Front and Rear Endbells. CE Models are fully suppressed.

Pump: Four chamber diaphragm positive displacement design; Self-priming up to 6 ft. suction lift; Pump able to run dry without damage; Removable port to hose connectors.

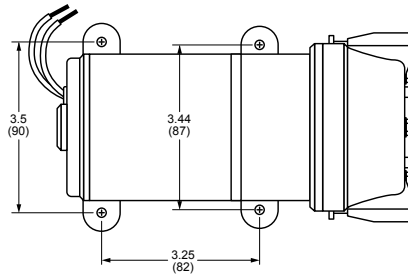

Model 4125 Series

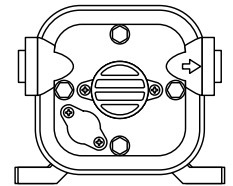
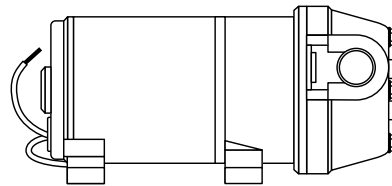

Pump Series	Dimensions - Inches (mm)			Weight lb. (kg)
	Height	Width	Length	
4105-XXX	3.75 (95)	6.3 (160)	8.2 (208)	3.9 (1.8)
4125-XXX	3.75 (95)	6.3 (160)	9.9 (252)	6.0 (2.8)

MODEL*	VOLTS	AMP DRAW @ 10 psi (0.7 bar)	FLOW GPM (l/min)	STRAINERS INCLUDED
4105-501	12V dc	3.6	3.3 (12.5)	Yes
4105-503	24V dc	1.8	3.3 (12.5)	Yes
4125-502	12V dc	8.5	5.0 (18.9)	Yes
4125-504	24V dc	3.6	5.0 (18.9)	Yes

* CE fully suppressed models are identified by a prefix “R” and a CE mark on the label. (i.e. R4105-501). Self Declaration Of Conformance (SDOC) is available upon request.

OPERATION

Your “Quad II” bait tank pump is designed to selfprime up to 6 feet suction lift and fill your tank in 8-12 minutes. This allows 5 to 6 water changes per hour. If pump fills tank in less than 8 minutes, divert excess water by installing a T or Y valve. Reduce turbulence by adding additional inlet at waterline or drill out multiple stand pipe holes so water does not spurt out of holes. Your lively bait need calm, fresh water.

This pump is quiet running. It is recommended you utilize a “lighted” on-off switch so that the pump is turned off when not in use. The “Quad II” is able to run

dry (no liquid) for extended periods with no damage to the pump. However, this could cause needless battery drain.

For general purpose or diesel transfer, plug in your choice of ports and lock in with slide clips. Attach hoses and wiring.

For portable use we recommend the pump be attached to a base (ie. 3/4” x 8” x 10” board or plywood), add a toggle switch, a length of two conductor cable with alligator clips for battery connection.

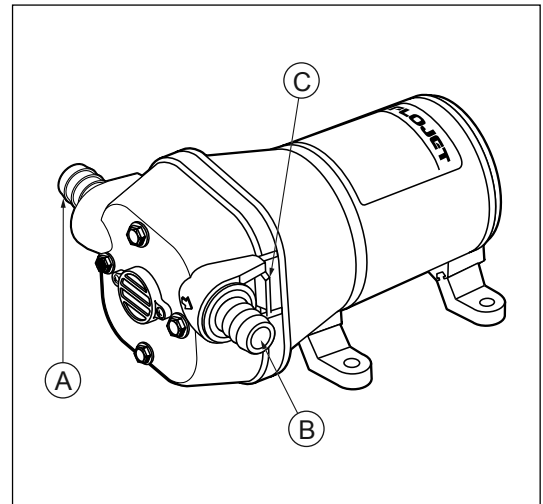
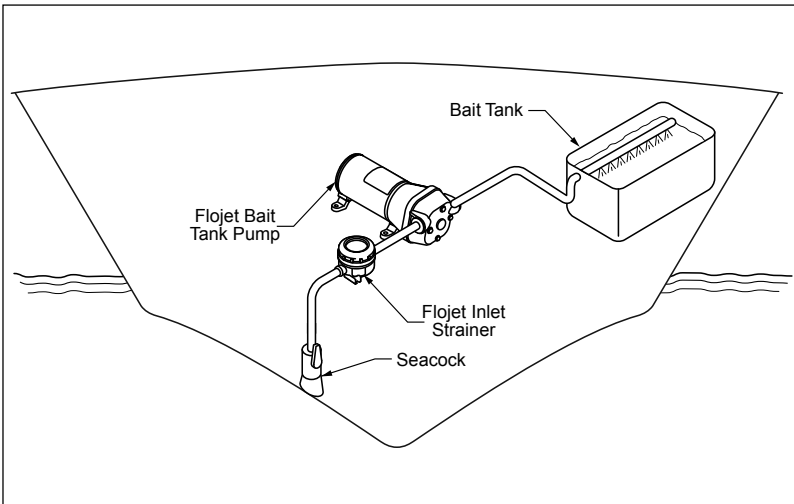

INSTALLATION

STEP 1

Remove shipping plugs from Quad pump ports. Some water from factory testing may spill out.

STEP 2

Install inlet A and discharge B port connectors. Firmly push slide clips C forward to lock port connectors in place.

STEP 3

Slide rubber mounts fully into 4 mounting tracks.

STEP 4

Mount pump vertically, with pump head down or horizontally in an accessible location. If mounting vertically, motor up, attach motor mounts first, then pump head mounts, while supporting weight of pump.

STEP 5

Use 3/4" I.D. flexible hose (preferably braided or reinforced). Use hose clamps on the slip-on barb hose connectors.

STEP 6

Install a 3/4" in line strainer #01610-000 in accessible location between sea cock and pump inlet.

This strainer or equivalent is required for pump warranty to be valid.

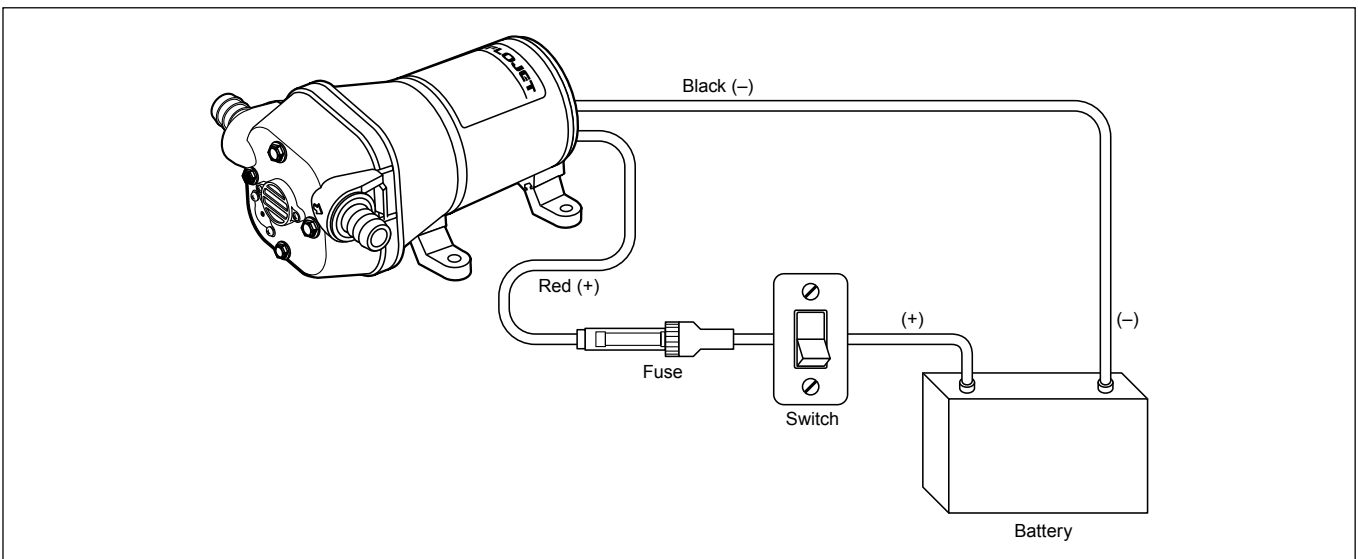

WIRING

STEP 1

Use 14 gauge stranded wire to 20', 12 gauge to 50', from power source.

STEP 2

Use a 10-15 amp rated (lighted) on-off switch on the (+) positive (red) motor lead.

STEP 3

Install 10 amp fuse protection in the positive switched lead for the -501 and -504 models, use a 15 amp fuse for the -502 and a 5 amp fuse for the -503 model.

TROUBLESHOOTING

WARNING: BEFORE SERVICING PUMP, TURN OFF PUMP AND DRAIN WATER FROM SYSTEM!!

Failure to Prime - Motor operates, but no pump discharge

- Restricted intake or discharge line
- Air leak in intake line
- Debris in pump
- Punctured pump diaphragm (pump leaks)
- Crack in pump housing

Motor falls to turn on

- Blown fuse
- Pump circuit has no power
- Loose wiring connection
- Defective motor

Low Flow and Pressure

- Air leak at pump intake
- Accumulation of debris inside pump and plumbing
- Worn pump bearing (excessive noise)
- Punctured pump diaphragm (pump leaks)
- Defective motor

Pulsating Flow

- Restricted pump delivery. Check discharge lines, fittings and valves for clogging or undersizing

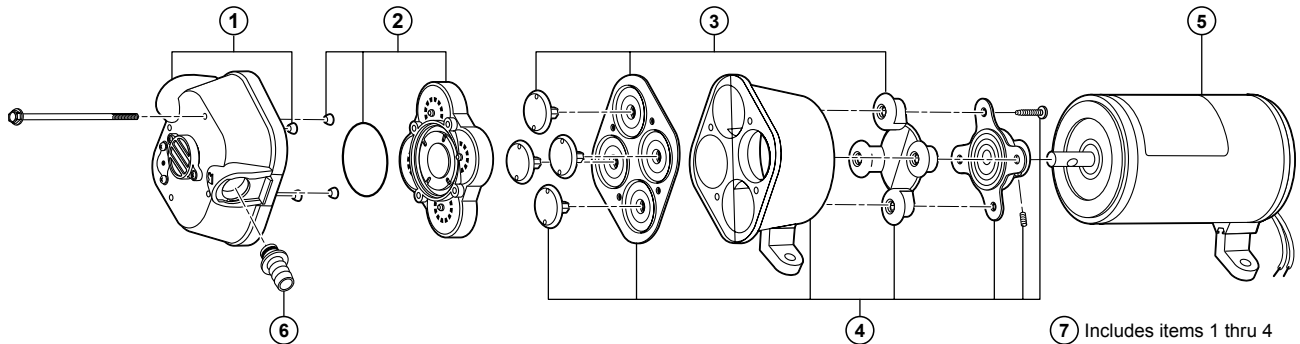

Quite often when a pump is worn or defective the one failed component has overburdened others. To avoid frequent aggravating repairs, Flojet offers service kit assemblies making repairs as quick and easy as possible.

DISASSEMBLE

Upper Housing

1. Loosen but do not remove four pump head screws and carefully remove upper housing assembly (1)
2. Inspect check valve (2) for debris
3. Reassemble new upper housing (1)

Check Valve Assembly

Follow step 1

3. Replace check valve (2)
4. Reassemble upper housing (1)

Lower Housing, Diaphragm, Motor

Follow step 1

3. Rotate lower housing (4) so mounting notch opening on lower housing exposes set screw which holds bearing housing to shaft.
4. Loosen this setscrew by inserting wrench 1/8" Allen wrench into mounting notch opening. Then, slide lower housing (4) off motor shaft.

Diaphragm Cont'd

5. Loosen four cam piston screws with Phillips head screw driver and pull apart cam from inner pistons. (Pistons should always be replaced when a new diaphragm is installed.)

Motor Cont'd

5. Replace Motor

REASSEMBLE

Motor

1. Reassemble lower housing assembly (4) to motor. (Follow steps 4 to 10.)

Diaphragm

2. Lower housing is assembled with:

- Flat side of diaphragm and outer pistons facing motor
 - Hex stem of inner pistons must be aligned into hex holes in outer pistons (4)
 - Outer pistons must be aligned with alignment slots on cam assembly making sure screw holes align in cam assembly, otherwise diaphragm will leak
3. Tighten cam piston screws partially, center piston in diaphragm, then tighten screws securely (18 in. lbs. torque)

Lower Housing

4. Reassemble lower housing assembly (4) to motor.
5. Retighten set screw securely. Set screw head must be positioned facing motor covering seam (indentation). (Positioning of this screw is critical to avoid misalignment and subsequent diaphragm damage.)

Upper Housing Check Valve

6. Reassemble upper housing (1)
7. Properly seat O-Ring in check valve assembly (2) and check if ferrules and screen are in place on upper housing (1)
8. Install check valve (2) into upper housing (1) and push in.
9. Assemble on to lower housing (4), align 4 screws on to motor by rotating lower housing (4) if necessary to align feet
10. Tighten screws evenly to 30 in. lbs. torque.

BAIT TANK AND GENERAL PURPOSE PUMPS SERVICE PARTS

KEY	DESCRIPTION	MODEL#			
		4105-501	4125-502	4105-503	4125-504
0	Service Kit*	20409-054	20409-054	20409-054	20409-054
1	Upper Housing With Clips	20404-005	20404-005	20404-005	20404-005
2	Check Valve Assembly	20407-010	20407-010	20407-010	20407-010
3	Diaphragm Assembly (includes screws)	20403-050	20403-050	20403-050	20403-050
4	Lower Housing Assembly	20419-005	20419-003	.20419-005	20419-003
5	Motors 12 volt D.C.	2009-079A	2009-080A	—	—
	Motors 12 volt D.C. CE Models	R2009-079A	R2009-080A	—	—
	Motors 24 volt D.C.	—	—	2019-026A	2019-027A
	Motors 24 volt D.C. CE Models	—	—	R2019-026A	R2019-027A
6	Ports - .75 HB (2)	20381-012	20381-012	20381-012	20381-012
	Ports - Garden Hose (2)	20381-013	20881-013	20381-043	20381-013
7	Pump Head Assembly	20406-013A	20406-005A	20406-013A	20406-005A
8	Side Clips (pair)	20408-000	20408-000	20408-000	20408-000

*Service Kit includes #2, #3, #8 and drive cam assembly.

ACCESSORIES

QUICK CONNECT PORT SYSTEM

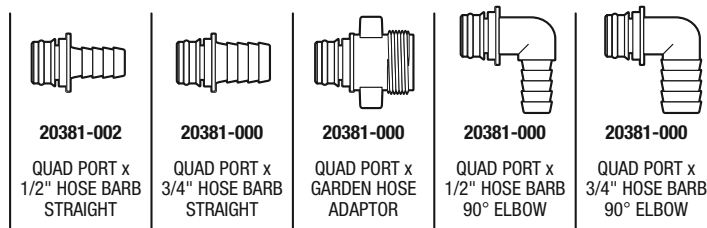

The above part numbers are packaged with 2 fittings per bag.

STRAINERS

Pump Series	Strainer Number	Inlet	Outlet	Screen
4105-501	1740-000	3/4 Barb	3/4 Barb	40 Mesh
4105-503	1740-000	3/4 Barb	3/4 Barb	40 Mesh
4125-502	1740-000	3/4 Barb	3/4 Barb	40 Mesh
4125-504	1740-000	3/4 Barb	3/4 Barb	40 Mesh

WARRANTY

FLOJET warrants this product to be free of defects in material and/or workmanship for a period of one year after purchase by the customer from FLOJET. During this one year warranty period, FLOJET will at its option, at no charge to the customer, repair or replace this product if found defective, with a new or reconditioned product, but not to include costs of removal or installation. No product will be accepted for return without a return material authorization number. All return goods must be shipped with transportation charges prepaid. This is only a summary of our Limited Warranty. For a copy of our complete warranty, please request Form No. 100-101.

RETURN PROCEDURE

Prior to returning any product to FLOJET, call customer service for an authorization number. This number must be written on the outside of the shipping package. Place a note inside the package with an explanation regarding the reason for return as well as the authorization number. Include your name, address and phone number.

Flojet

U.S.A.
Flojet
20 Icon
Foothill Ranch, CA 92610-3000
Tel: (949) 859-4945
Fax: (949) 859-1153

UNITED KINGDOM
Jabsco/Flojet
Bingley Road, Hoddesdon
Hertfordshire EN11 OBU
Tel: +44 (0) 1992 450145
Fax: +44 (0) 1992 467132

CANADA
Fluid Products Canada
55 Royal Road
Guelph, Ontario N1H 1T1
Tel: (519) 821-1900
Fax: (519) 821-2569

JAPAN
NHK Jabsco Company Ltd.
3-21-10, Shin-Yokohama
Kohoku-Ku, Yokohama, 222
Tel: 045-475-8906
Fax: 045-475-8908

GERMANY
Jabsco GmbH
Oststrasse 28
22844 Norderstedt
Tel: +49-40-53 53 73-0
Fax: +49-40-53 53 73-11